

Mounting accessories XLB-xxx-yy

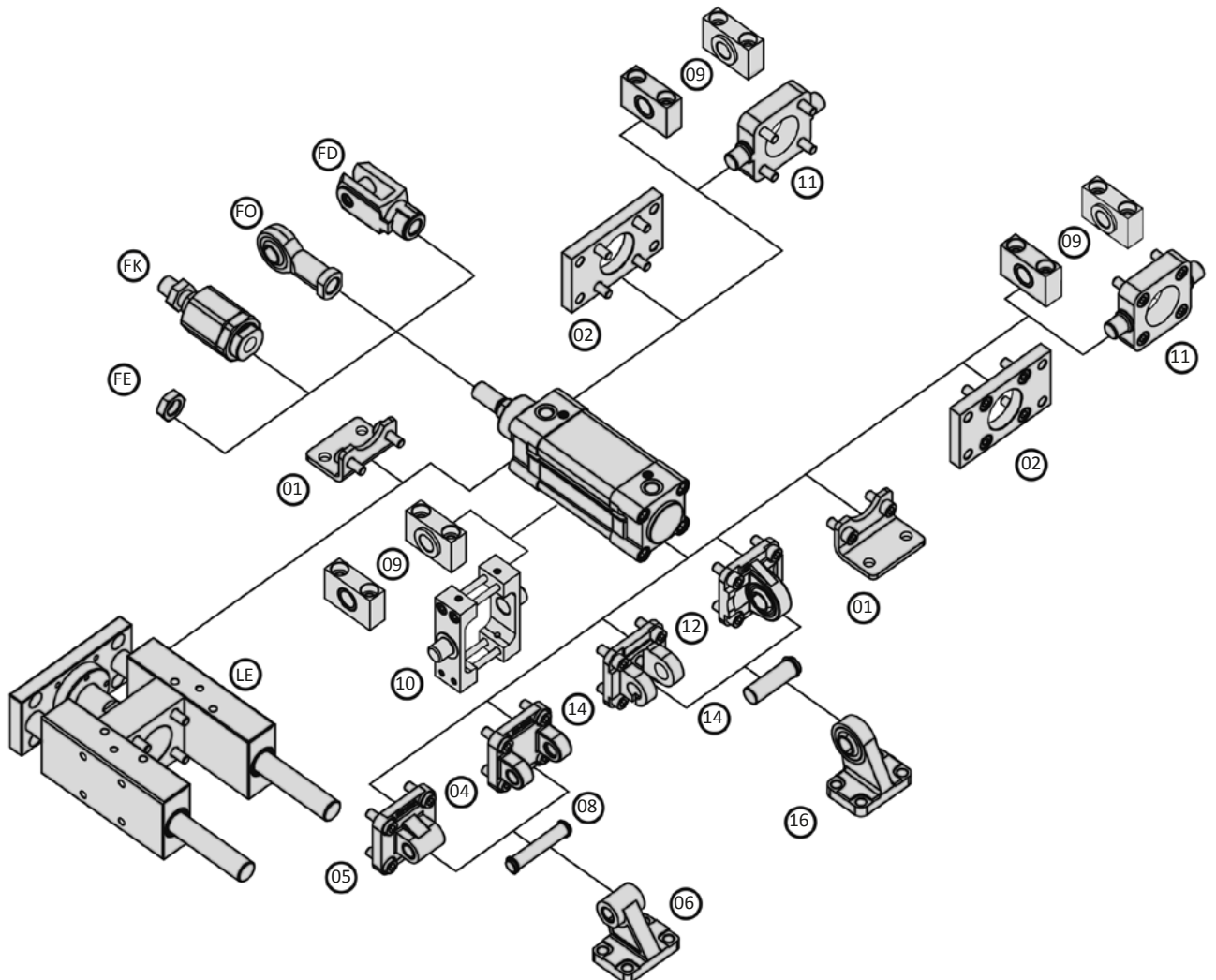

Series XL Mounting accessories

XLB-xxx-01 Foot mount

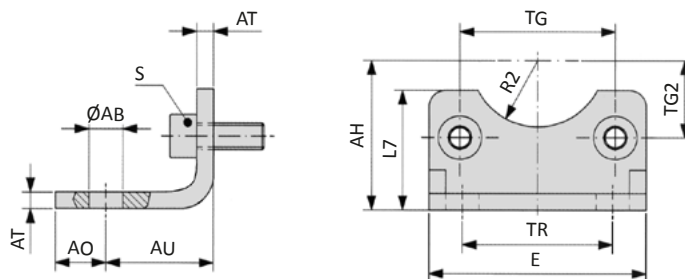

Model-no.:	Ø AB	AH	AO	AU	AT	E	L7	R2	S	TG	TG2	TR
XLB-032-01	7	32	11	24	4	45	30	15	M6 x 16	32.5	16.25	32
XLB-040-01	10	36	8	28	4	52	30	17.5	M6 x 16	38	19	36
XLB-050-01	10	45	15	32	5	65	36	20	M8 x 20	46.5	23.25	45
XLB-063-01	10	50	13	32	5	75	35	22.5	M8 x 20	56.5	28.25	50
XLB-080-01	12	63	14	41	6	95	47	22.5	M10 x 20	72	36	63
XLB-100-01	14.5	71	16	41	6	115	53	27.5	M10 x 20	89	44.5	75
XLB-125-01	16.5	90	25	45	8	140	70	30	M12 x 25	110*	55	90
<i>tolerances and adjustments</i>	H14	JS16		± 0.2				H15		± 0.2 *± 0.3		JS14

Material: steel, zinc plated; 2 x 2 screws in accordance with EN ISO 4762 are included.

XLB-xxx-02 Flange mount

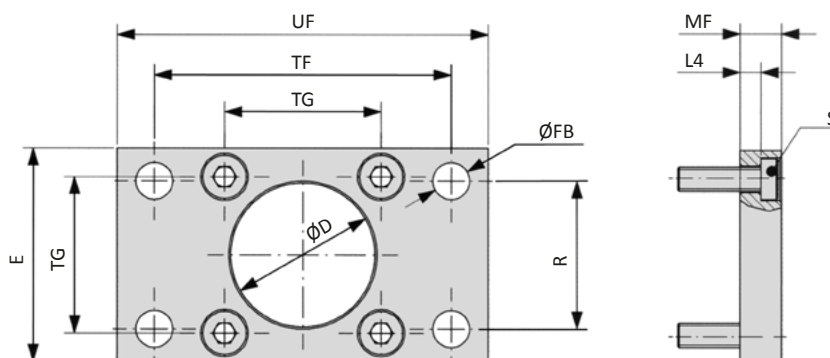
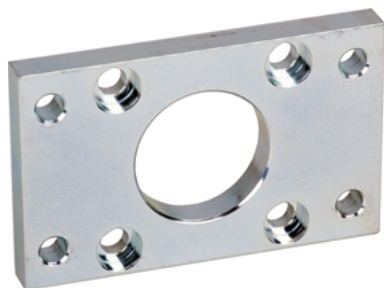

Model-no.:	Ø D	E	Ø FB	L4	MF	R	S	TF	TG	UF
XLB-032-02	30	45	7	5	10	32	M6 x 20	64	32.5	80
XLB-040-02	35	52	9	5	10	36	M6 x 20	72	38	90
XLB-050-02	40	65	9	6.5	12	45	M8 x 20	90	46.5	110
XLB-063-02	45	75	9	6.5	12	50	M8 x 20	100	56.5	120
XLB-080-02	45	95	12	9	16	63	M10 x 25	126	72	150
XLB-100-02	55	115	14	9	16	75	M10 x 25	150	89	170
XLB-125-02	60	140	16	10.5	20	90	M12 x 25	180	110*	205
<i>tolerances and adjustments</i>	H11		H13	- 0.5	JS14	JS14		JS14	± 0.2 *± 0.3	

Material: steel, zinc plated; 4 screws in accordance with DIN 7984 are included.

XLB-xxx-04 Clevis mount with bushing



Inclusive clevis pin
order no: XLB-xxx-48

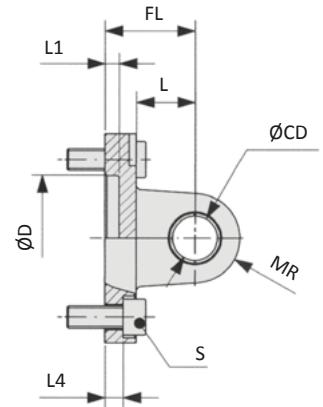
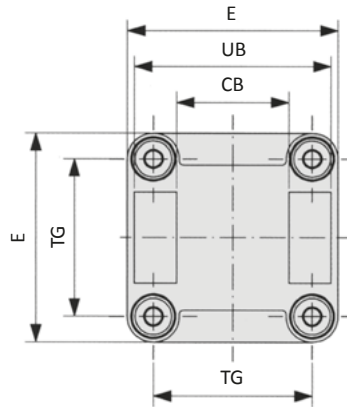

Model-no.:	CB	Ø CD	Ø D	E	FL	L	L1	L4	MR	S	TG	UB
XLB-032-04	26	10	30	45	22	13	5	5.5	10	M6 x 20	32.5	45
XLB-040-04	28	12	35	52	25	16	5	5.5	12	M6 x 20	38	52
XLB-050-04	32	12	40	65	27	16	5	6.5	12	M8 x 20	46.5	60
XLB-063-04	40	16	45	75	32	21	5	6.5	16	M8 x 20	56.5	70
XLB-080-04	50	16	45	95	36	22	5	10	16	M10 x 25	72	90
XLB-100-04	60	20	55	115	41	27	5	10	20	M10 x 25	89	110
XLB-125-04	70	25	60	140	50	30	7	10	25	M12 x 25	110*	130
<i>tolerances and adjustments</i>	H14	H9	H11		± 0.2			± 0.5			± 0.2 *± 0.3	h13

Materials: Al, bushing steel and PTFE; 4 screws in accordance with EN ISO 4762 are included.

XLB-xxx-05 Swivel mount

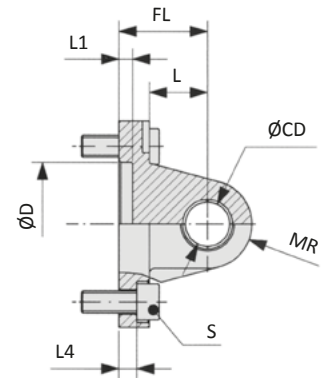
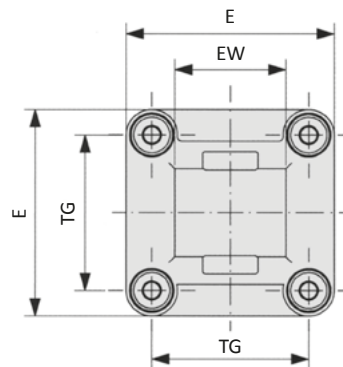

Model-no.:	Ø CD	Ø D	E	EW	FL	L	L1	L4	MR	S	TG
XLB-032-05	10	30	45	26	22	13	5	5.5	10	M6 x 20	32.5
XLB-040-05	12	35	52	28	25	16	5	5.5	12	M6 x 20	38
XLB-050-05	12	40	65	32	27	16	5	6.5	12	M8 x 20	46.5
XLB-063-05	16	45	75	40	32	21	5	6.5	16	M8 x 20	56.5
XLB-080-05	16	45	95	50	36	22	5	10	16	M10 x 25	72
XLB-100-05	20	55	115	60	41	27	5	10	20	M10 x 25	89
XLB-125-05	25	60	140	70	50	30	7	10	25	M12 x 25	110*
<i>tolerances and adjustments</i>	H9	H11			± 0.2			± 0.5			± 0.2 *± 0.3

Materials: Al, bushing steel and PTFE; 4 screws in accordance with EN ISO 4762 are included.

Series XL Mounting accessories

XLB-xxx-06 Swivel mount 90°

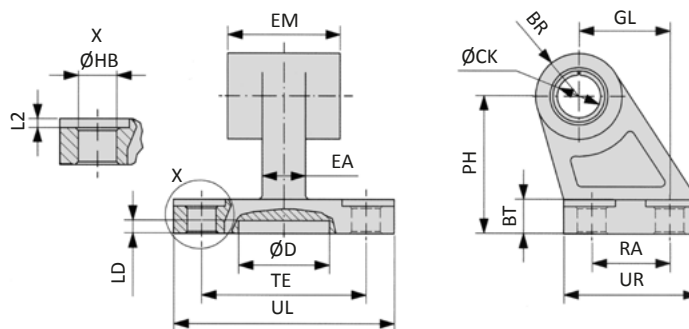

Model-no.:	BR	BT	ØCK	Ø D	EA	EM	GL	ØHB	L2	LD	PH	RA	TE	UL	UR
XLB-032-06	10	8	10	21	10	26	21	6.6	1.6	3	32	18	38	51	31
XLB-040-06	11	10	12	21	15	28	24	6.6	1.6	3	36	22	41	54	35
XLB-050-06	13	12	12	21	16	32	33	9	1.6	3	45	30	50	65	45
XLB-063-06	15	14	16	21	16	40	37	9	1.6	3	50	35	52	67	50
XLB-080-06	15	14	16	21	20	50	47	11	2.5	3	63	40	66	86	60
XLB-100-06	19	17	20	11	20	60	55	11	2.5	3	71	50	76	96	70
XLB-125-06	22.5	20	25	21	30	70	70	14	3.2	3	90	60	94	124	90
<i>tolerances and adjustments</i>			H9				JS14	H13			JS15	JS14	JS14		

Materials: Al, bushing steel and PTFE

XLB-xxx-08 Clevis pin

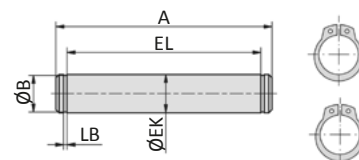

Model-no.:	A	Ø B	Ø EK	EL	LB
XLB-032-08	53	9.6	10	46	1.1
XLB-040-08	60	11.5	12	53	1.1
XLB-050-08	68	11.5	12	61	1.1
XLB-063-08	78	15.2	16	71	1.1
XLB-080-08	98	15.2	16	91	1.1
XLB-100-08	118	19	20	111	1.3
XLB-125-08	139	23.9	25	132*	1.3
<i>tolerances and adjustments</i>			e8	+2 *+3	

Material: steel, zinc plated; 2 snap rings are included.

XLB-xxx-09 Bearing block

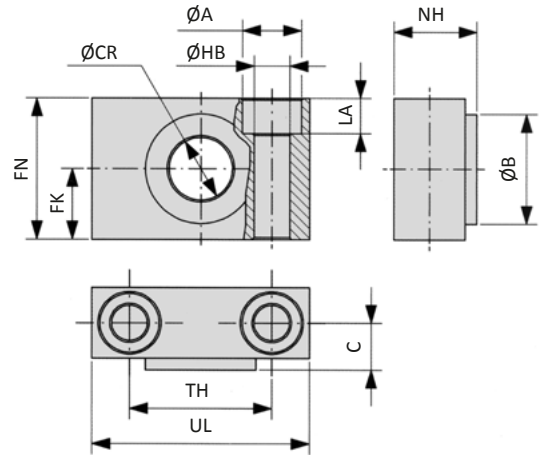
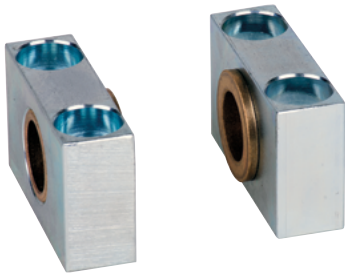

Model-no.:	Ø A	Ø B	C	Ø CR	FK	FN	Ø HB	LA	NH	TH	UL
XLB-032-09	11	22	10.5	12	15	30	6.6	7	18	32	46
XLB-040-09	15	28	12	16	18	36	9	9	21	36	55
XLB-063-09	18	32	13	20	20	40	11	11	23	42	65
XLB-100-09	20	39	16	25	25	50	14	13	28.5	50	75
<i>tolerances and adjustments</i>				H9	± 0.1		H13			± 0.2	

Materials: Al, bronze bushing

XLB-xxx-10 Trunnion mount

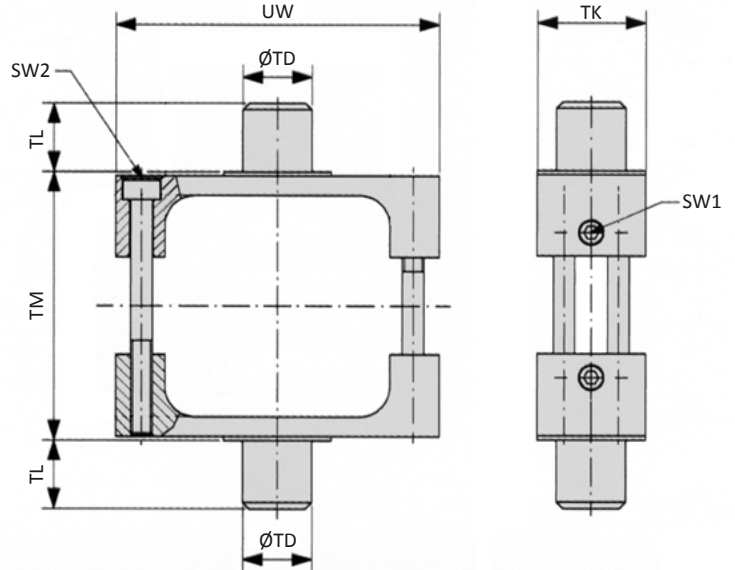
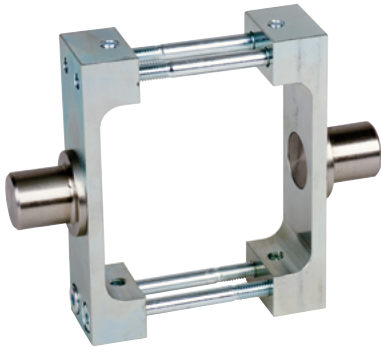

Model-no.:	SW1	SW2	Ø TD	TK	TL	TM	UW
XLB-032-10	3	2.5	12	25	12	50	65
XLB-040-10	3	3	16	25	16	63	75
XLB-050-10	3	4	16	30	16	75	95
XLB-063-10	3	4	20	30	20	90	105
XLB-080-10	3	4	20	30	20	110	130
XLB-100-10	4	5	25	40	25	132	145
XLB-125-10	4	6	25	40	25	160	175
<i>tolerances and adjustments</i>			e9		h14	h14	

Material: steel, zinc plated

Series XL Mounting accessories

XLB-xxx-11 Trunnion mount

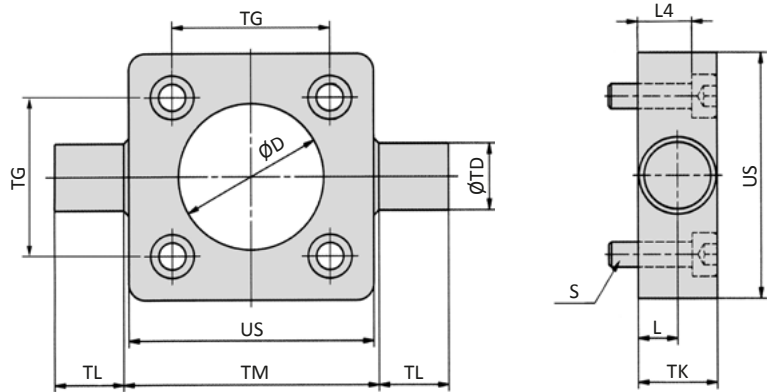
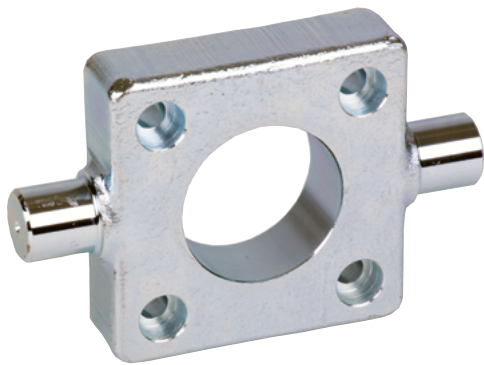

Model-no.:	Ø D	L	L4	S	Ø TD	TG	TK	TL	TM	US
XLB-032-11	30	6.5	8	M6 x 20	12	32.5	14	12	50	46
XLB-040-11	35	9	13	M6 x 25	16	38	19	16	63	59
XLB-050-11	40	9	11	M8 x 25	16	46.5	19	16	75	69
XLB-063-11	45	11.5	16	M8 x 30	20	56.5	24	20	90	84
XLB-080-11	45	11.5	14	M10 x 30	20	72	24	20	110	102
XLB-100-11	55	14	19	M10 x 35	25	89	29	25	132	125
XLB-125-11	60	15	18	M12 x 35	25	110*	30	25	160	150
<i>tolerances and adjustments</i>	H 11	+ 0.2			e9	± 0,2 *± 0,3		h14	h14	

Material: steel, zinc plated; 4 screws in accordance with EN ISO 4762 are included.

XLB-xxx-12 Swivel mount with spherical bearing

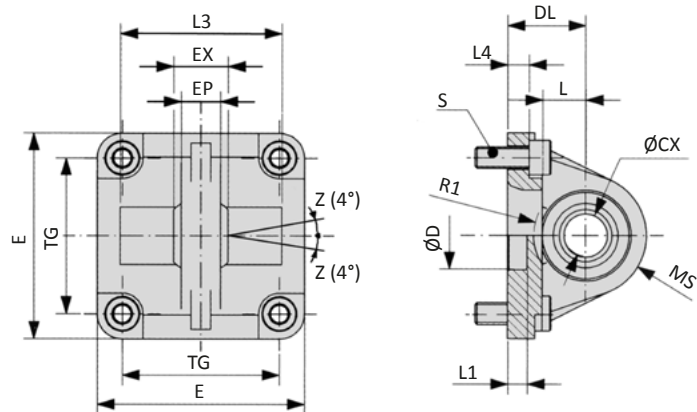
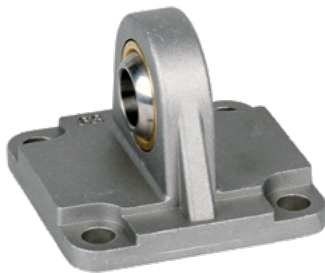

Model-no.:	Ø CX	Ø D	DL	E	EP	EX	L	L1	L3	L4	MS	R1	S	TG
XLB-032-12	10	30	22	45	10.5	14	12	7	-	5.5	16	-	M6 x 20	32.5
XLB-040-12	12	35	25	52	12	16	15	7	-	5.5	18	-	M6 x 20	38
XLB-050-12	16	40	27	65	15	21	15	7	51	6.5	21	19	M8 x 20	46.5
XLB-063-12	16	45	32	75	15	21	20	7	-	6.5	23	-	M8 x 20	56.5
XLB-080-12	20	45	36	95	18	25	20	9	74	10	28	24	M10 x 25	72
XLB-100-12	20	55	41	115	18	25	25	9	-	10	30	-	M10 x 25	89
XLB-125-12	30	60	50	140	25	37	30	9	-	10	40	-	M12 x 25	110*
<i>tolerances and adjustments</i>	H7	H11	± 0.2			± 0.1				± 0.5				± 0.2 *± 0.3

Materials: Al, bearing steel, bronze bushing; 4 screws in accordance with EN ISO 4762 are included.

XLB-xxx-14 Clevis mount small with pin

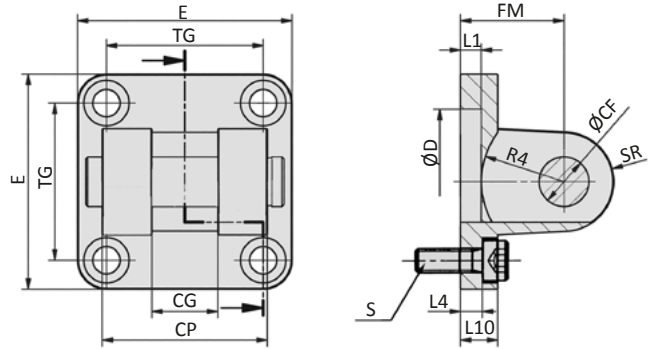
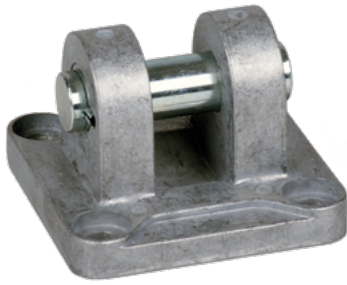

Model-no.:	Ø CF	CG	CP	Ø D	E	FM	L1	L4	L10	R4	S	SR	TG
XLB-032-14	10	14	34	30	45	22	5	5.5	9	17	M6 x 20	10	32.5
XLB-040-14	12	16	40	35	52	25	5	5.5	9	20	M6 x 20	12	38
XLB-050-14	16	21	45	40	65	27	5	6.5	11	22	M8 x 20	14	46.5
XLB-063-14	16	21	51	45	75	32	5	6.5	11	25	M8 x 20	18	56.5
XLB-080-14	20	25	65	45	95	36	5	10	14	30	M10 x 25	20	72
XLB-100-14	20	25	75	55	115	41	5	10	14	32	M10 x 25	22	89
XLB-125-14	30	37	97	60	140	50	7	10	20	42	M12 x 25	25	110*
<i>tolerances and adjustments</i>	F7	D10	d12	H11		± 0.2		± 0.5					± 0.2 *± 0.3

Materials: Al, bushing steel and PTFE, clevis pin steel, zinc plated; 4 screws in accordance with EN ISO 4762 are included.

RD-xx, FD-xxx Rod clevis

Spring loaded pin (RD-25, FD-40...80)

Clevis pin with snap rings (FD-125)

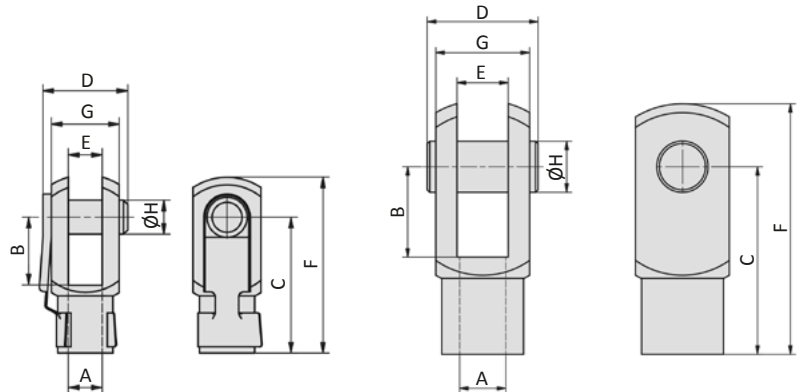

Model-no.:	for cylinder	A	B	C	D	E	F	G	Ø H
RD-25	XL-032	M10 x 1.25	20	40	26	10	52	20	10
FD-40	XL-040	M12 x 1.25	24	48	32	12	62	24	12
FD-63	XL-050, XL-063	M16 x 1.5	32	64	40	16	83	32	16
FD-80	XL-080, XL-100	M20 x 1.5	40	80	50	20	105	40	20
FD-125	XL-125	M27 x 2	54	110	65	30	148	55	30

Material: steel, zinc plated

Series XL Mounting accessories

FK-xxx Flexible coupling

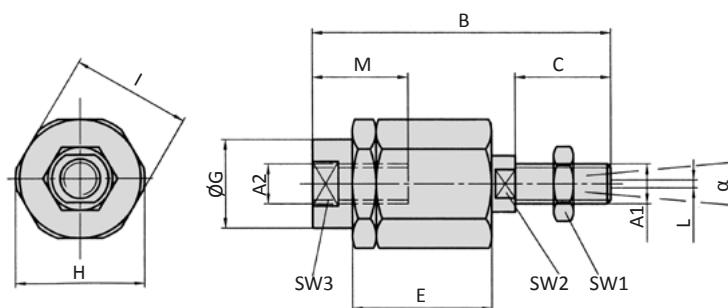

Model-no.:	for cylinder	A1, A2	B	C	D	E	Ø G	H	I	L	M	SW1	SW2	SW3	α
FK-32	XL-032	M10 x 1.25	71.5	20	7.5	35	22	32	30	2	22	17	12	19	8°
FK-40	XL-040	M12 x 1.25	71.5	20	7.5	35	22	32	30	2	22	19	12	19	8°
FK-63	XL-050, XL-063	M16 x 1.5	104	32	10	53	32	45	41	2	30	24	20	27	6°
FK-80	XL-080, XL-100	M20 x 1.5	119	40	10	53	32	45	41	2	37	30	20	27	6°
FK-125	XL-125	M27 x 2	147	54	10	60	57	70	65	2	48	41	24	54	8°

Material: steel, zinc plated

RO-xx, FO-xxx Rod eye

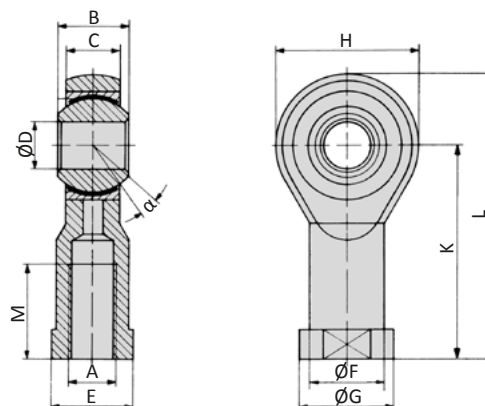

Model-no.:	for cylinder	A	B	C	Ø D	E	Ø F	Ø G	H	K	L	M	α
RO-25	XL-032	M10 x 1.25	14	10.5	10	17	15	19	28	43	57	20	13°
FO-40	XL-040	M12 x 1.25	16	12	12	19	17.5	22	32	50	66	22	13°
FO-63	XL-050, XL-063	M16 x 1.5	21	15	16	22	22	27	42	64	85	28	15°
FO-80	XL-080, XL-100	M20 x 1.5	25	18	20	30	27.5	34	50	77	102	33	14°
FO-125	XL-125	M27 x 2	37	25	30	41	40	50	70	110	145	51	17°

Materials: steel, zinc plated, bearing steel, bronze bushing